

BIGBAT

12V. 17 Ah.

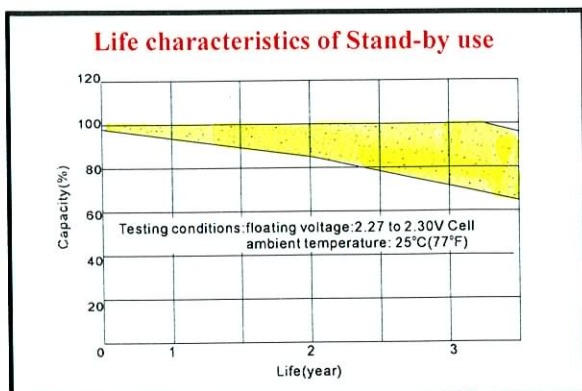
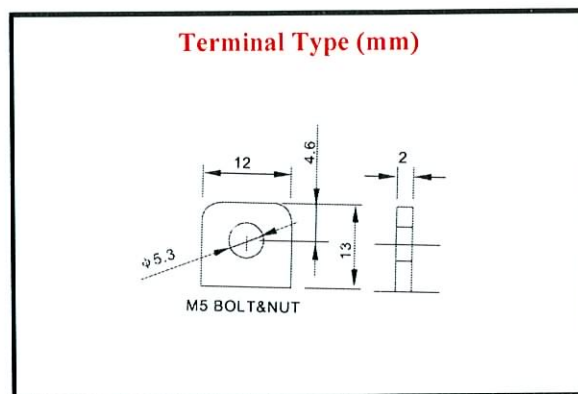
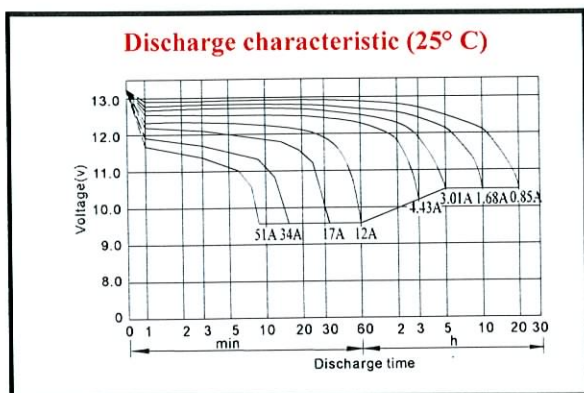
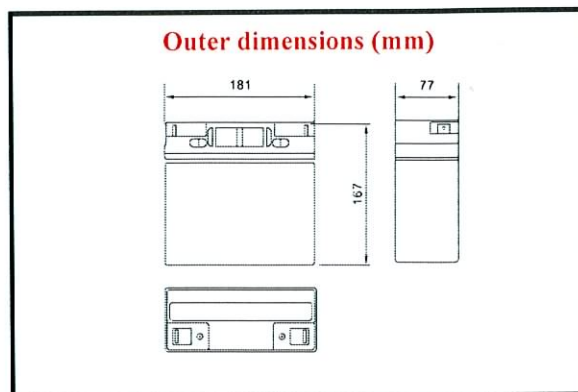

Characteristics

Capacity 25° C (77° F)	20 hour rate (0.85 A) 10 hour rate (1.68 A) 5 hour rate (3.01 A) 1 hour rate (12.00 A)	17.00 AH 16.80 AH 15.05 AH 12.00 AH
	1.5 hour discharge to 10.5V	6.8 A
Internal Resistance	Full charged battery at 25° C (77° F)	14 m Ω
Capacity effected by temperature (20 hour rate)	40° C (104° F)	102 %
	25° C (77° F)	100 %
	0° C (32° F)	85 %
	-15° C (5° F)	65 %
Self-discharge at 25° C (77° F)	Capacity after 3 month storage	91 %
	Capacity after 6 month storage	82 %
	Capacity after 12 month storage	64 %
Charge (constant voltage)	Cycle	Initial charging current less than 5.6 A Voltage 14.50 – 14.90V.
	Float	Voltage 13.60 – 13.80V.

